



at&t

Your world. Delivered.

Synapse™

Quick Start Guide

AT&T SB67040 Cordless Accessory Handset



Charger Installation



This Quick Start Guide provides installation, registration and some operating instructions so you can start using your SB67040 Cordless Handset. For more information see the Synapse User's Guide at www.telephones.att.com/SynapseGuides

The SB67040 Cordless Handset uses a rechargeable 2.4v nickel-metal hydride cell (NiMH) pack and comes with a battery charger. Place the SB67040 Cordless Handset in the charger when not in use.

To install the SB67040 Cordless Handset Charger:

1. Plug the power adapter into an electrical outlet not controlled by a wall switch.
2. Plug the small end of the power adapter into the jack on the underside of the charger.
3. Route the cord through the slot as shown in Figure 1.

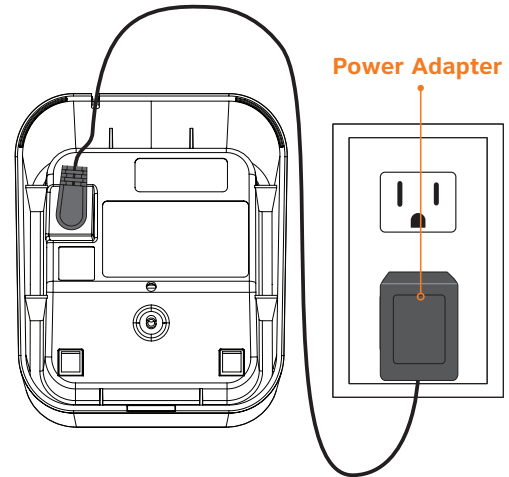

Figure 1. Handset Charger Power Connect

Battery Installation

To install the SB67040 Cordless Handset battery:

1. Remove the battery cover as shown in Figure 2.
2. Plug the battery connector securely into the plug inside the Handset battery compartment, matching the color-coded label.
3. Place the battery in the compartment with **THIS SIDE UP** facing up.
4. Align the cover flat against the battery compartment, then slide it upwards until it clicks into place.

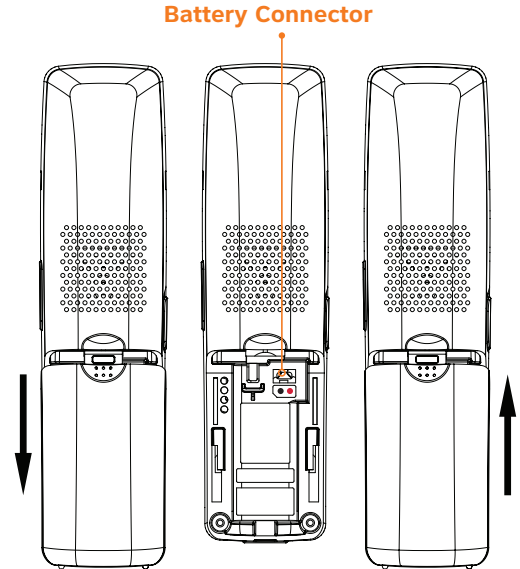

Figure 2. Install Handset Battery

Battery Installation (Continued)

To install the SB67040 Cordless Handset battery: (Continued)

5. The LCD displays a blank screen during startup.
 - After startup, if there is some charge in the battery, the LCD displays the **Place in charger** screen shown in Figure 3.
 - If the screen is blank, place the Handset in the charger.

NOTE: For customer service or product information, contact your installer at the number on the cover of this guide. If your installer is unavailable, visit our website at www.telephones.att.com/smb or call **1 (888) 916-2007**. In Canada dial **1 (888) 883-2474**.

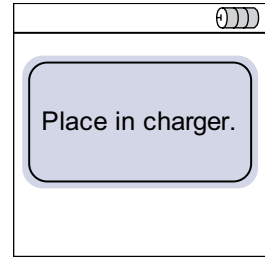

Figure 3. Place in Charger Screen

Battery Charging

To charge the Handset battery:

1. Place the Handset in the charger as shown in Figure 4.
 - The **CHARGE** light will be on when the Handset is charging.
 - The **REGISTER** screen shown in Figure 5 should display within 15 seconds.

NOTE: Charge the Handset battery for at least 16 hours before use. When fully charged, the Handset battery provides approximately five hours of talk time or three days of standby time.

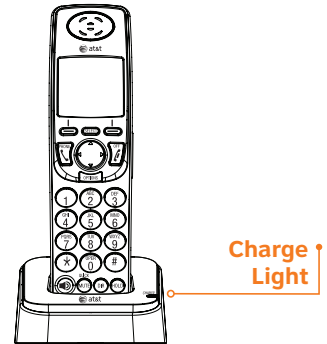

Figure 4. Handset in Charger



Figure 5. Register Screen

Handset Registration

This procedure provides instructions for registering a SB67040 Cordless Accessory Handset. Only one Cordless Handset and one Cordless Headset can be registered to a Deskset.

To register the SB67040 Cordless Handset:

If the Handset is not registered to a Deskset, the **Place in charger** notification screen shown in Figure 6 displays upon powering up.

1. Place the Handset into the charger. The **REGISTER** Handset screen shown in Figure 7 displays.

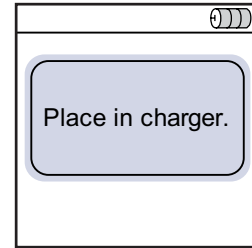

Figure 6. Place In Charger Screen

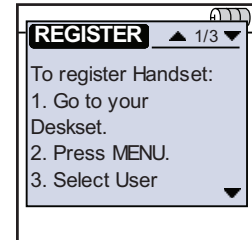

Figure 7. Register Screen

Handset Registration (Continued)

To register the SB67040 Cordless Handset: (Continued)

2. Press **MENU** on the SB67030 Deskset.
3. Press **2** on the Deskset.
4. Press **6** on the Deskset to display the Cordless Settings menu shown in Figure 8. The screen reflects whether the Handset and Headset are registered.
5. Press **1** on the Deskset to begin the registration process.
6. To register the Handset press **Register** as shown in Figure 9.
 - Once the Handset registration begins, the Handset and Deskset display **Registration in Progress** screens.

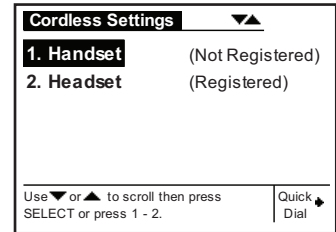

Figure 8. Cordless Registration



Figure 9. Register Cordless

Handset Registration (Continued)

To register the SB67040 Cordless Handset: (Continued)

- If the registration process times out, the Handset displays **Registration Failed** as shown in Figure 11, generates an error tone, and resets. Try registration again.
- When registration is complete, the Deskset and Handset display **Handset Registered** and the Handset generates confirmation tones. Figure 10 shows the Handset messages.

7. Press **Exit** to return to the Cordless Settings screen.

NOTE: The registration process on both Deskset and Handset will end after two minutes. If registration is not successful, try again.



Figure 10. Handset Registered

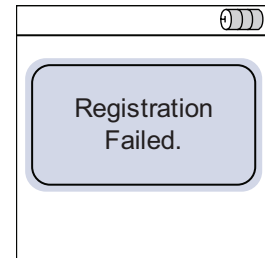

Figure 11. Registration Failed

Handset Registration (Continued)

To deregister the Handset:

1. Perform Steps 2 through 4 of the "To register the SB67040 Cordless Handset:" procedure on page 7.
2. Press **1** on the Deskset to begin the deregistration process.
3. To deregister the Handset, press **DeReg**, as shown in Figure 12.
4. To confirm deregistration, press **YES**. Press **NO** to keep the Handset registered.
5. To return to the Cordless Settings screen, press **Exit**.



Figure 12. Deregistration Screen

Handset Overview

The optional SB67040 Cordless Handset duplicates many of the Deskset features. Figures 13 and 14 illustrate and describe the keys for the SB67040 Cordless Handset.

Soft Keys

Label in display changes according to the current task.

Phone

Starts or answers a call.

Options

Accesses options depending on the current mode.

Mute/Quick

Mutes the handset microphone while on an active or conference call. Pressing and holding accesses Quick Dial numbers.

Speaker

Generates dial tone in Idle mode. Toggles audio to and from speaker during active call.

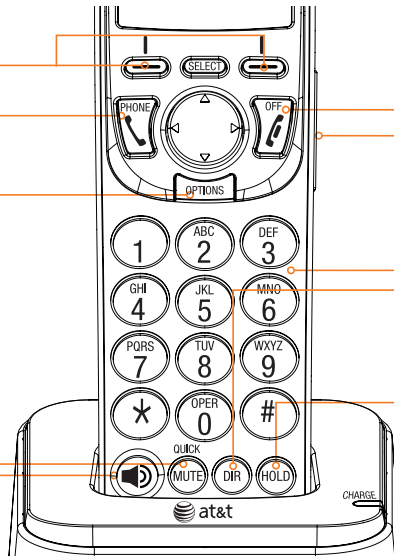

Off

Ends current call.

◀ Volume ▶ (On side)

Decreases and increases the ringer or incoming voice volume.

Dial pad, 0-9, *,

Dials, performs shortcuts, or accesses areas in a list.

DIR

Accesses the Directory.

Hold

Places active call on hold.

Figure 13. SB67040 Cordless Handset Key Functions

Handset Overview (Continued)

Select

Selects an option out of a menu or list.

Navigate Left ◀

Scrolls or cycles through list entries. Performs backspace function. Use during message playback to jump back eight seconds in message. Adjusts display contrast level.

Navigate Down ▾

Scrolls through list entries. Highlights new messages or new calls in Idle mode. Use during message playback to play next message.

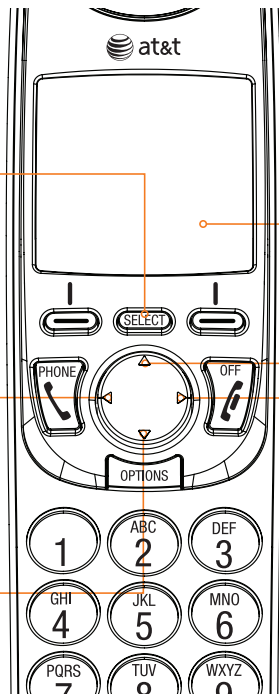

Liquid Crystal Display (LCD)

Provides instructions and status information.

Navigate Up ▲

Scrolls through list entries. Highlights new messages or new calls in Idle mode. Use during message playback to play previous message.

Navigate Right ▶

Scrolls or cycles through list entries. Use during message playback to jump forward eight seconds in message. Adjusts display contrast level.

Figure 14. SB67040 Cordless Handset Key Functions (Continued)

Liquid Crystal Display (LCD)

The Idle screen shown in Figure 15 displays when the Handset is first registered. It also displays at the end of any operation such as completion of a call, or when the extension does not have any active or held calls.

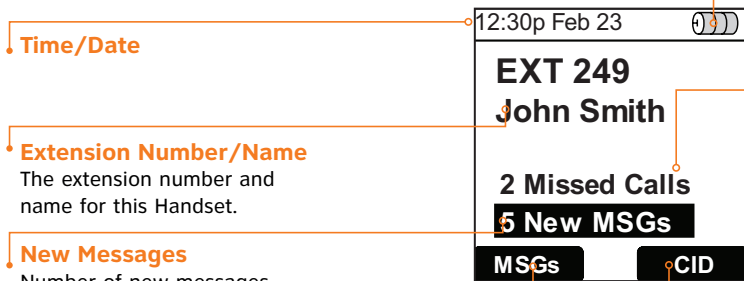

Figure 15. SB67040 Cordless Handset Idle Screen

Time/Date

Extension Number/Name

The extension number and name for this Handset.

New Messages

Number of new messages. Press **SELECT** when highlighted to see a Message Review screen similar to the one shown in Figure 21 on page 16. Once a new message is reviewed, the new message count on the Idle screen goes down by one.

NOTE: The Handset screen goes blank after 30 seconds of inactivity to save power. When the Handset is reactivated, there is a brief delay to allow it to update its status. No key presses are recognized during this update process.

Status Display

Displays battery status, Do Not Disturb, Call Forward and Voicemail full indicators when applicable.

Missed Calls

Number of new missed calls. Press **SELECT** when highlighted to see them.

Soft Key Labels

Press the key below **MSGs** to see the Message Review screen shown in Figure 21 on page 16. Press the key below **CID** to see entire call log.

Predialing

You can predial a phone number before pressing **PHONE** or **SPEAKER**. In this mode the Handset produces no dial tone. You can also predial from a list.

To make a call while the Handset is on hook:

1. To initiate predialing as shown in Figure 16, press any dial pad key. Dial **9** for an outside call.
2. Enter telephone number using dial pad keys. You have the following options:
 - To delete a digit and move the cursor back one space, press the left **navigation** key.
 - To insert a two-second pause, press **Pause**.
 - Press **Cancel** or **OFF** at any time to terminate the dialing sequence. The Handset returns to Idle.
3. Press **PHONE** to go off hook and dial the Predial digits.

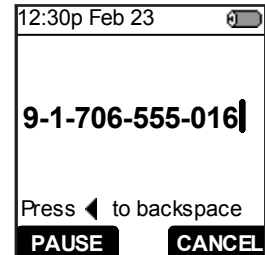

Figure 16. Predial Mode

Live Dialing

Live dialing refers to making a call when the phone is off hook.

To make a call off hook:

1. Press **PHONE** or **SPEAKER** to initiate a call as shown in Figure 17.
2. Enter telephone number using dial pad keys. Dial **9** for an outside call. Hyphens are automatically inserted for all 7, 8, 10, and 11 digit dialing, except when **9** is followed by a zero for an international call.

NOTE: If you enter **9** followed by another digit other than **1**, **XFER** replaces **EXT_#s**, and **CONF** replaces **CID** as shown in Figure 18.

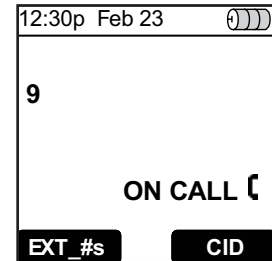

Figure 17. Live Dial

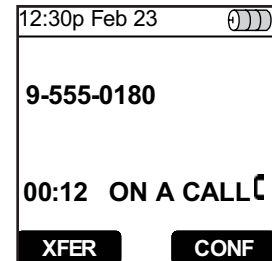

Figure 18. External Call Live Dial

Answering a Call

If the system receives an incoming call in Idle mode, the Handset rings and the incoming call information displays as shown in Figure 19. The screen displays caller name and number (if available). If there is more than one incoming call, they are displayed on the screen. To cycle through incoming calls, press the up or down navigation key.

The SB67040 Handset records incoming call information in the Call Log and displays notification on the Idle screen. A call that has not been reviewed is considered new. Once you review a call in the Call Log, the call count goes down by one. If there are no new calls, the notification will display **0 New Missed Calls**.

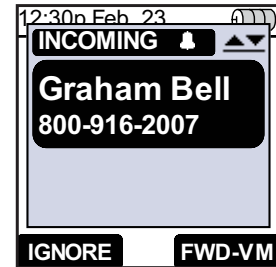

Figure 19. Incoming Call

You have the following options when there is an incoming call:

- To answer a call, press **SELECT, PHONE** or **SPEAKER**.
- To silence the ringer, press **Ignore**.
- To forward the call to voicemail, press **FWD-VM**.

NOTE: Press **◀ VOLUME ▶** to increase or decrease the ringer volume.

Retrieve Voicemail

To retrieve voicemail:

1. To retrieve all voicemail, press **MSGs** from the Idle screen.
 - If you have created a user password, you will be prompted to enter it, as shown in Figure 20.
 - The Message Review screen is displayed, as shown in Figure 21.
2. To begin playing the voicemail, press **PLAY**.
3. To return to the Idle screen, press **EXIT**.

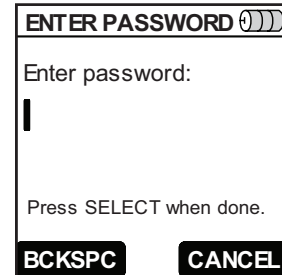

Figure 20. Retrieve Voicemail



Figure 21. Message Review



www.telephones.att.com/smb

© 2010 Advanced American Telephones. All Rights Reserved.
AT&T, the AT&T logo and the slogan "Your world. Delivered." are
trademarks of AT&T Intellectual Property licensed to Advanced
American Telephones, San Antonio, TX 78219. Synapse™ is a
trademark of Advanced American Telephones.

Printed in China Issue 7.0 7/10